



Large Carousel Turntables

Introducing movement from Movetech UK to the showroom will bring the excitement of an exhibition to the sales floor, helping to attract customers and increasing sales. Our larger carousels will allow you to create stunning displays with lots of impact.



Maxi Plus Carousel range

Our Maxi Plus Carousel range are well suited to generating simple, but unique, full circular platform displays, or they can be combined with other movement in our range and, for instance, imaginative lighting effects, to create something really special that stops customers in their tracks.



There are two versions of our standard Maxi Plus Carousels: the Maxi 1000 which is 1m in diameter and has a maximum distributed load of up to 500kg, and the Maxi 1500 which is 1.5m in diameter with a maximum distributed load of up to 700kg.

 **PLEASE NOTE:** Maximum display properties assume evenly distributed load.









Extension Kits

Extensions kits are available to increase the display area diameter up to 1.8m, 2.5m or 3m in diameter. The 1.8m kit can only be used with the 1m Maxi Plus Carousel units including the D-006-MP1000, D-006-MP1000U and D-006-MP1000.Multi. The 2.5 or 3m extension kit can only be used with the 1.5m Maxi Plus Carousel units including the D-006-MP1500 and D-006-MP1500.Multi. If you require more help, don't hesitate to contact our Sales and Technical teams.



Useful Information

-  **Rotating direction:** Clockwise or Anti-clockwise.
-  **Speed of rotation:** Variable approximately 0.6-1.1 RPM (0-6 – 8RPM for 'Ultra' units).
-  **Supply:** Mains powered featuring 5 amp slip rings. UK 3-pin plug (alternatives available).
-  **Power:** 220/240v AC 50hz 40 watts (excluding slip rings).
-  **Decks:** Unfinished MDF decks are available from stock (1m, 1.5m, 2.5m, 3m).

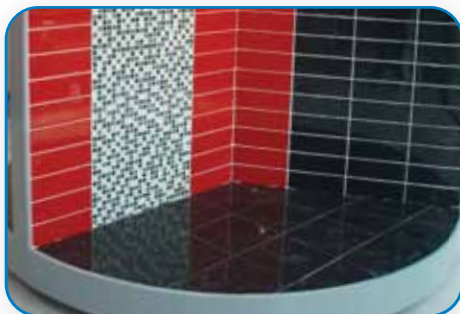

Multi-functional Control Units



Multi-functional control units offer additional options such as **oscillation** and **hesitation** modes. The control allows the user to define the run mode, in addition to the rotational direction (clockwise/anti-clockwise). Rotational speed can also be defined on the control panel. The control is simple and easy to use and all modes are controlled via switches/knobs situated on the units multi-function control box.

Multi-functional control product specifications can be found on page 3, see: 'D-006-MP1000.Multi' and 'D-006-MP1500.Multi'



Specifications

Product code	Product description	Unit dimensions			Max. display properties		
		Diameter (m)	Height (mm)	Weight (kg)	Diameter (m)	Height (m)	Capacity* (kg)
D-006-MP1000	Maxi Plus Carousel 1m Display Turntable	1	210	53	1	2.44	500
D-006-MP1000U	Maxi Plus Ultra Carousel 1m Display Turntable	1	230	60	1	2.44	300
D-006-MP1000.Multi	Maxi Plus Carousel 1m Display Turntable with Multi-Functional Control	1	230	60	1	2.44	300
D-006-MP1800Ext	Maxi Plus Carousel Extension Kit : 1m – 1.8m	1 - 1.8	210	16.5	1.8	2.44	500
D-006-MP1500	Maxi Plus Carousel 1.5m Display Turntable	1.5	210	73	1.5	2.44	700
D-006-MP1500.Multi	Maxi Plus Carousel 1.5m Display Turntable with Multi-Functional Control	1.5	210	73	1.5	2.44	700
D-006-MP2500Ext	Maxi Plus Carousel Extension Kit : 1.5m – 2.5m	1.5 - 2.5	210	43	2.5	2.44	700
D-006-MP3000Ext	Maxi Plus Carousel Extension Kit : 1.5m – 3m	1.5 - 3	210	93	3	2.44	700
D-006-MaxiSPA	Static pole adaptor for Maxi and Maxi Plus range	-	-	-	-	-	-

* Maximum evenly distributed load  = For use with D-006-MP1000, D-006-MP1000U and D-006-MP1000.Multi  = For use with D-006-MP1500 and D-006-MP1500.Multi

ALTERNATIVE OPTION: Maxi Plus Lightweight Carousel Turntable. Lightweight, without slip rings, plywood deck as standard - see BTF490 for details.

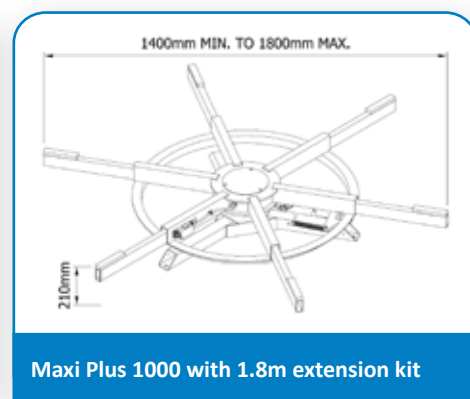
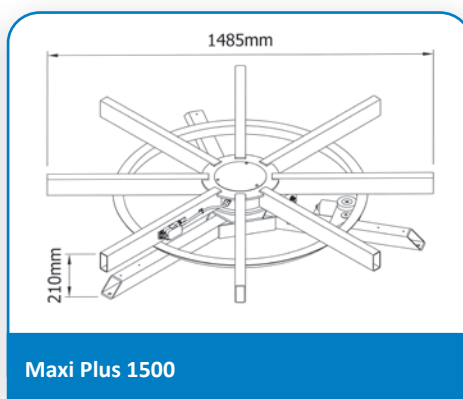
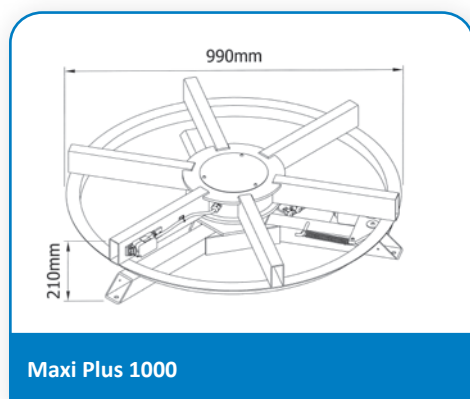



You might also be interested in...

Revolving Stage Turntables

In the retail and exhibition industries movement adds a dynamic dimension to product display. For the events, film and TV industries a Movetech UK revolving stage turntable can create spectacular film sequences or TV commercials. They can also be used to create impressive product launches and reveals by moving the audience/merchandise as required.



Revolving Signs

A revolving sign mechanism from Movetech UK can give you the competitive edge. Ideal for a wide variety of locations, both indoors and out, a revolving sign will attract attention, whether inside a shopping mall, an exhibition or on top of a multi-storey building.

Mini Carousels

Our Mini Carousel turntables are well suited to generating simple, full circular platform displays. They can also be combined with other movements in our range. For instance, imaginative lighting effects, to create something really special that stops customers in their tracks.



Small Carousel Turntables

Our small carousel range includes the Mini Carousel, B25 range and B200 range. The B25 range is a fully finished, versatile and reliable mains powered turntable range, ideal for creating compact window or counter displays. The B200 range offers heavier duty display turntables suitable for more substantial displays.